

PT SERIES PERIMETER TRIMS

Specify as: SOFTFORMS® Perimeter Trim

Model No. PT-X

MATERIAL: Aluminum alloy.....6063 T5 or equal
Finish..... **Semi-Gloss White**

The extruded aluminum profile shall incorporate a continuous integral fin top and bottom for surface contact to conventionally installed acoustical ceiling tiles, or a separate flange for attachment to gypsum drywall. The fins shall be 3/4" wide and shall be untapered to the edge.

Two or more areas shall be incorporated into the back of each extrusion, with a series of continuous extruded grooves to provide a greater bonding surface for joinery.

The extruded profiles shall be factory painted to match standard ceiling grid finish.

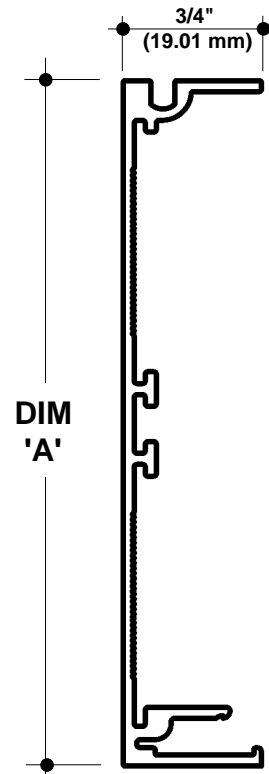

TYPICAL SECTION **Perimeter Trim**
NO SCALE

SELECTING YOUR PROFILE FROM THE SOFTFORMS® PT SERIES OF ALUMINUM EXTRUSIONS

| PT Model | Height at Face | Minimum Radii |
|----------|---------------------|----------------------|
| PT-2 | 2-1/8" (53.9 mm) | 12" Single Radius |
| PT-4 | 3-7/8" (98.4 mm) | 12" Single Radius |
| PT-6 | 5-25/32" (146.8 mm) | 12" Single Radius |
| PT-8 | 7-13/16" (198.4 mm) | 12" Single Radius |
| PT-10 | 9-13/16" (249.2 mm) | 24" Single Radius |
| PT-12 | 12" (304.8 mm) | 24" Single Radius |
| PT-KE | 6" (152.4 mm) | Not Available Curved |

Optional Factory Finishes

- Face clad with mirror finish stainless steel
- Face clad with matte or high gloss plastic laminate finishes
- Face clad with Acrovyn® PVC laminate finishes
- Face clad with finished or unfinished wood veneers
- Painted in a high gloss polyurethane finish
- Painted in a Corafon® fluoropolymer finish
- Clear satin, bronze, or black anodized finish
- Primed finish for field painting

Corafon® is a registered trademark of PPG Industries, Inc.
Acrovyn® is a registered trademark of Construction Specialties, Inc.

PT-6 Radiused Trim Available in Inside and Outside Radii. Can be Combined to Form Serpentine Shapes. Minimum Radii Dependent on Trim Model. Consult Factory.

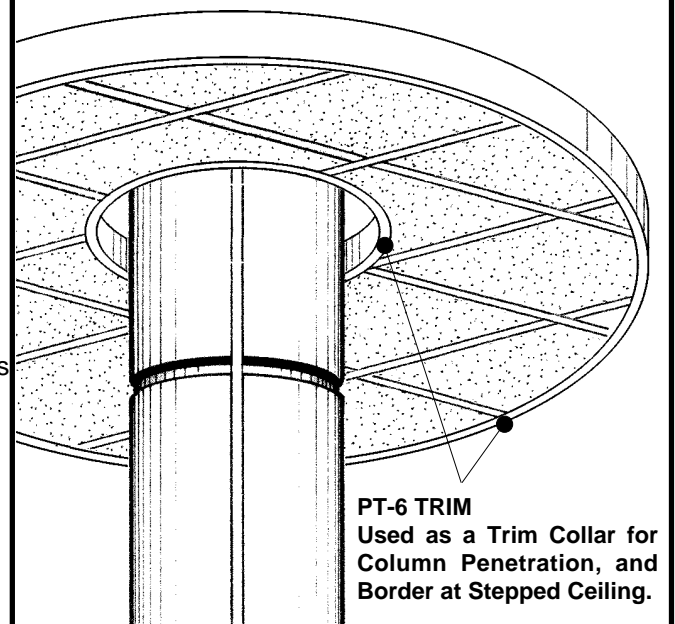

© 2008 Pittcon Industries

West

2090 Del Rio Way, Unit B
Ontario, CA 91761
Phone: (909) 773-0001
Fax: (909) 773-0091

3330 W. Flower Street
Phoenix, AZ 85017
Phone: (602) 233-9100
Fax: (602) 233-9400

**Pittcon
Industries**
DIVISION OF PITTCO ARCHITECTURAL METALS, LLC
800 637-7638

East

6409 Rhode Island Ave.
Riverdale, MD 20737
Phone: (301) 927-1000
Fax: (301) 699-8690

PT SERIES

PERIMETER TRIMS

An extruded aluminum perimeter trim offering flexible design and ease of installation. PT TRIMS can be used with acoustical or drywall ceilings, and are compatible with all major exposed grid systems. Create height transitions in your ceiling with custom serpentine, convex, or concave configurations, or as a lighting cove in conjunction with recessed lighting, and Pittcon's own series of CC-1-TF ceiling covers.

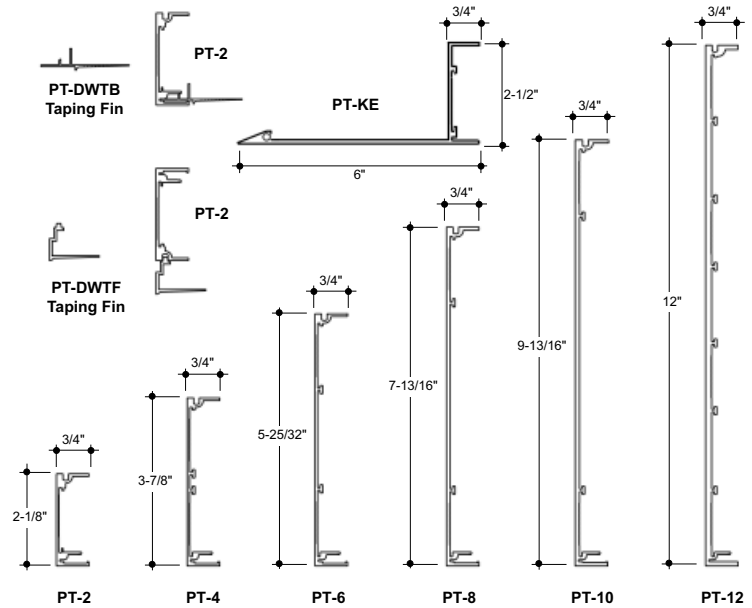
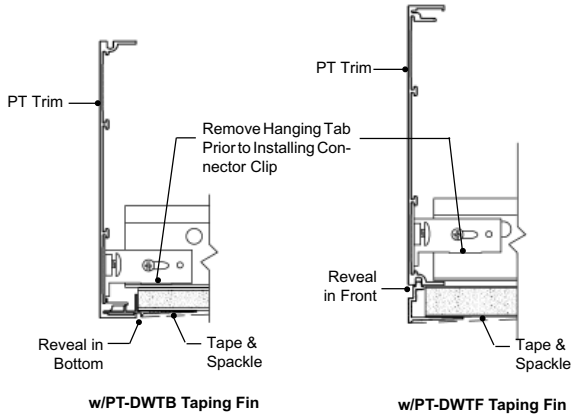

PT SERIES PROFILES

NO SCALE

SECTIONS

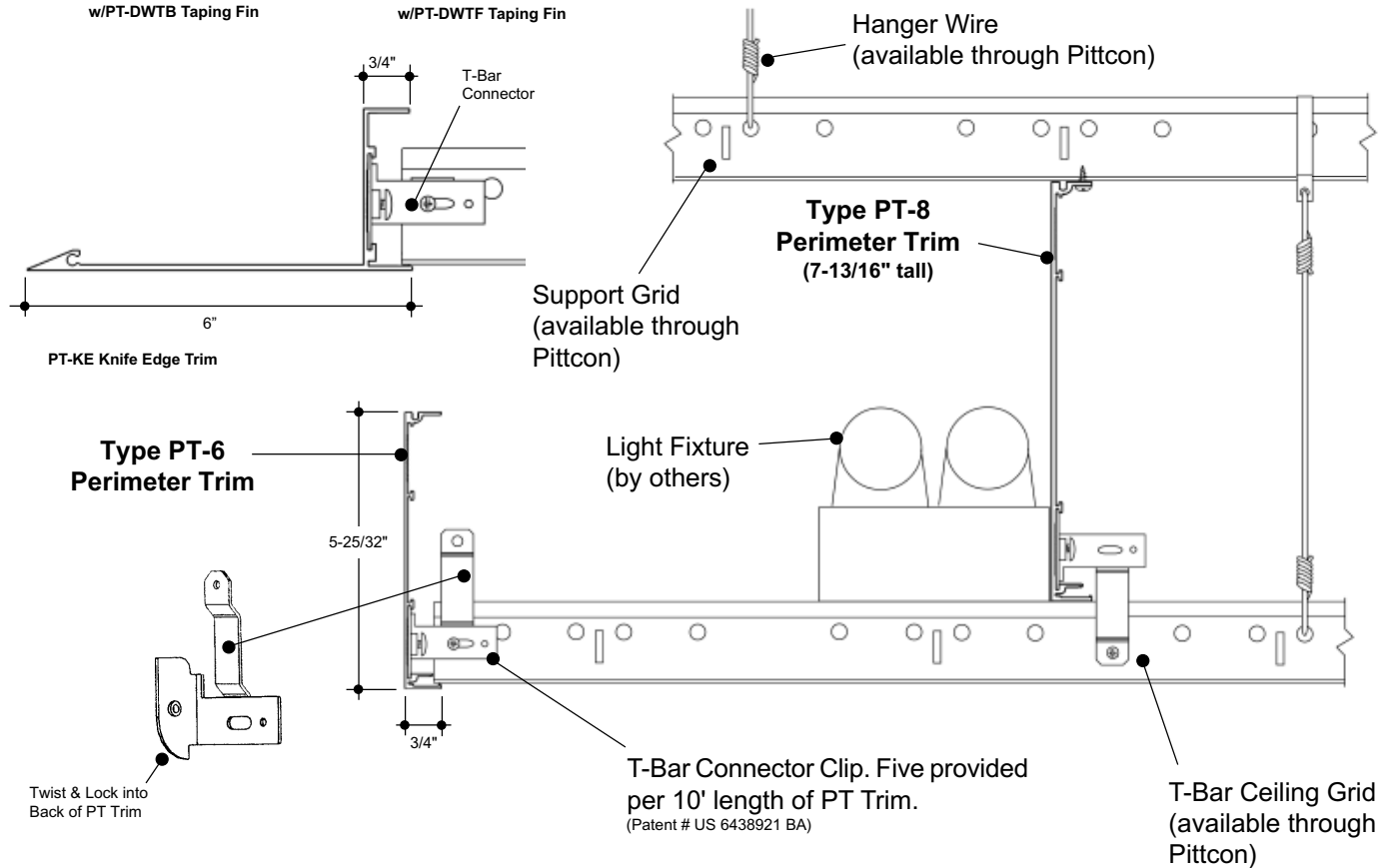

Pittcon Industries Division Pittcon Architectural Metals, LLC
 6409 Rhode Island Avenue Riverdale, Maryland 20737 (800) 637-7638 , (301) 927-1000 Fax: (301) 699-8690
 3330 W. Flower Street Phoenix, Arizona 85017 (800) 637-7638 , (602) 233-9100 Fax: (602) 233-9400
 © 2008 Pittcon Industries

Fabricated with Pride in

 Riverdale, Maryland-U.S.A.